

OPERATION, PARTS AND SAFETY MANUAL



PRHM-34 PUSH TYPE POWER COMBINATION STRAPPING TOOL

IMPORTANT! DO NOT DESTROY

It is the customer's responsibility to have all operators and servicemen read and understand this manual.

Contact your local Signode representative for additional copies of this manual.

READ ALL INSTRUCTIONS BEFORE OPERATING THIS SIGNODE PRODUCT

SIGNODE • 3620 WEST LAKE AVENUE • GLENVIEW, ILLINOIS 60025 U.S.A.

WARNING

READ THESE INSTRUCTIONS CAREFULLY. FAILURE TO FOLLOW THESE INSTRUCTIONS CAN RESULT IN SERIOUS PERSONAL INJURY.

STRAP BREAKAGE HAZARD

Improper operation of the tool or sharp corners on the load can result in strap breakage during tensioning, which could result in the following:

- A sudden loss of balance causing you to fall.
- Both tool and strap flying violently towards your face.

Failure to place the strap properly around the load or an unstable or shifted load could result in a sudden loss of strap tension during tensioning. This could result in a sudden loss of balance causing you to fall.

- If the load corners are sharp use edge protectors.
- Positioning yourself in-line with the strap, during tensioning and sealing, can result in serious personal injury from flying strap or tool. When tensioning or sealing, position yourself to one side of the strap and keep all bystanders away.

TRAINING

This tool must not be used by persons not properly trained in its use. Be certain that you receive proper training from your employer. If you have any questions contact your Signode Representative.

EYE INJURY HAZARD

Failure to wear safety glasses with side shields can result in serious eye injury or blindness. Always wear safety glasses with side shields which conform to American National Safety Institute standard Z87.1 or Euro Norm 166.



FALL HAZARD

Maintaining improper footing and/or balance when operating the tool can cause you to fall. Do not use the tool when you are in an awkward position.

CUT HAZARD

Handling strap or sharp parts could result in cut hands or fingers. Wear protective gloves.



TOOL CARE

- Inspect and clean the tool daily. Replace all worn or broken parts.
- Lubricate all moving parts weekly unless otherwise specified.
- On air powered tools, always disconnect the pneumatic connection to the tool when performing part removal and replacement procedures. **NEVER** connect a pneumatic source to a disassembled tool unless otherwise specified.

WORK AREAS

Keep work areas uncluttered and well lighted.

⚠ WARNING

READ THESE INSTRUCTIONS CAREFULLY. FAILURE TO FOLLOW THESE INSTRUCTIONS CAN RESULT IN SERIOUS PERSONAL INJURY.

- Use correct Signode products for your application. If you need help contact your Signode Representative.
- Signode tools and machines are designed and warranted to work together with Signode strapping and seals. Use of non-Signode strap and seals and/or manufactured or specified replacement parts may result in strap breakage or joint separation while applying strapping to a load or during normal shipping and handling. This could result in serious personal injury.

JOINT FORMATION

- Before using this tool, read its Operation and Safety instructions contained in this manual.
- This tool is a double reverse notch-joint sealers. Each notch-joint must be inspected to make certain it has four (4) good notches. A properly formed notch-joint will appear as shown in the illustration. If the notch-joint does not appear as shown, then the operator must proceed as follows.
 1. Make certain that the tool's operating instructions are being followed before applying another strap.
 2. Cut the strap off and apply a new strap and seal.
 3. An improper formed seal which does not have four (4) good notches, could result in strap separation. Before moving any package be certain that the seal is formed as shown. Inspect the joint to make certain it appears as shown in the illustration. If not, remove the broken strap and check the tool for worn or broken parts. Repair the tool for worn or broken parts. Repair the tool before applying another strap.

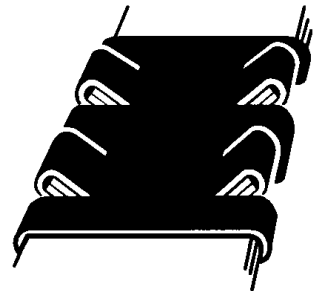

MOVING AND STACKING STRAPPED LOADS

Before moving or stacking any strapped load, follow all standard industry practices regarding safe material handling procedures.

CUTTING TENSIONED STRAP

Using claw hammers, crowbars, chisels, axes or simialr tools will cause tensioned strap to fly apart with hazardous force. Use only cutters designed for cutting strap. Read the instructions in the cutter's manual for proper procedures in cutting strap. Before using any Signode product read its Operation and Safety Manual.

TABLE OF CONTENTS	Page
General Safety Instructions	2
Specifications	4
Major Components	5
Recommended Air Line Piping	6
Maintenance	8
Set-Up for Tool Operation	9
Operating Instructions	10
Tool Parts Removal, Replacement and Adjustments	14
Tool Parts List	20
Air Motor Parts List	28
Troubleshooting	34
Tool Options	37
Declaration Of Conformity	39

 WARNING

Signode tools and machines are designed and warranted to work together with Signode strapping and seals. Use of non-Signode strap and seals and/or manufactured or specified replacement parts may result in strap breakage or joint separation while applying strapping to a load or during normal shipping and handling. This could result in serious personal injury.

PRHM-34
Part No. 306700



SPECIFICATIONS

MODEL	TYPE	STRAP		SEALS
		WIDTH	THICKNESS	
PRHM-34	MAGNUS, PAINT & WAX	3/4" (19mm)	0.025" (0.64mm) Minimum 0.031" (0.79mm) Maximum	34HOC

MAJOR TOOL COMPONENTS

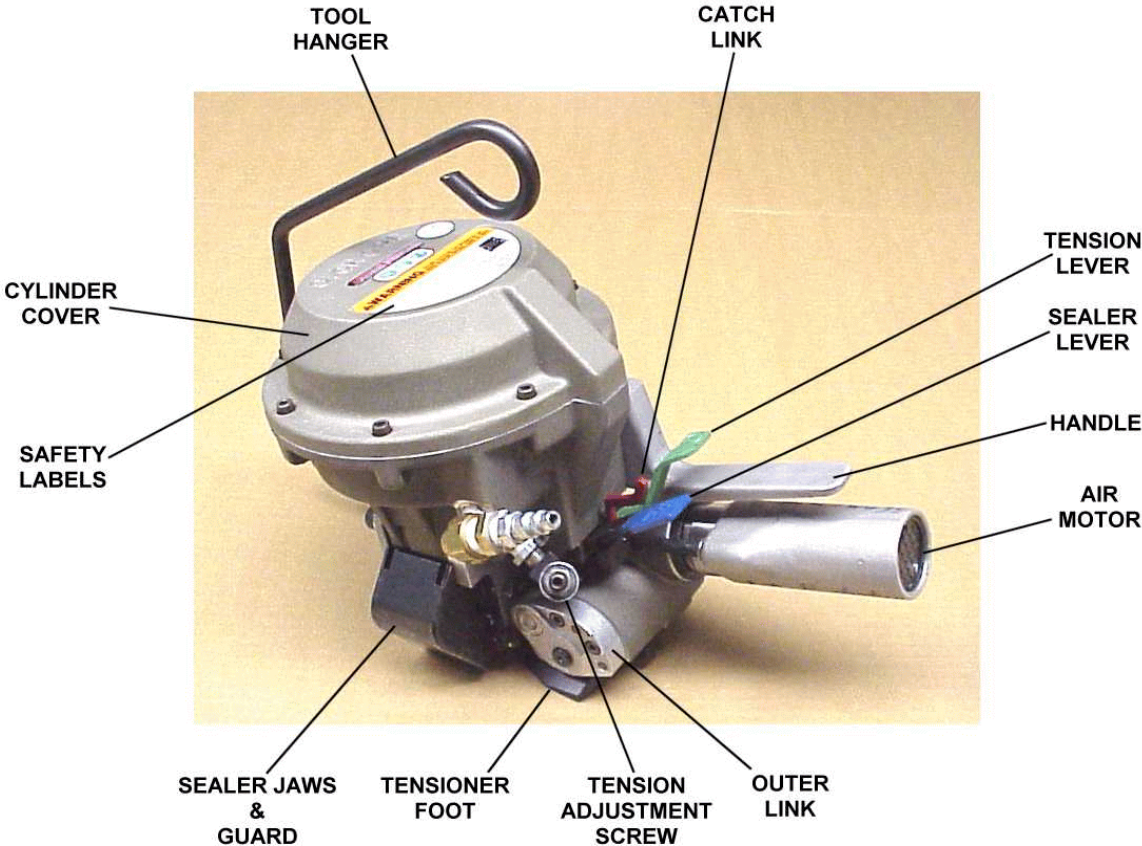

PNEUMATIC INFORMATION

AIR SUPPLY INSTALLATION

If compressor has a good dryer unit, use black pickled pipe. When a dryer unit is not installed, use galvanized or copper pipe.

To perform reliably, a pneumatic tool requires a continuous source of clean, water-free air at adequate pressure.

WARNING

- Never operate this tool using a bottled air or gas source.
- Bottled air/gas sources do not provide consistent operating pressure and could result in air pressures that exceed the maximum allowed for this tool.
- Exceeding the maximum allowable air pressure could result in serious personal injury.

A filter-regulator-lubricator unit (Signode Part No. 173111) must be installed as close to the air tool as possible, preferably within 10 feet (3M). It should be placed in a convenient location where it can easily be drained, adjusted, and filled with oil. The air hose must have at least a 1/4" (6.3mm) I.D. A quick-connect press-on socket is installed on the stress spring end of the hose for convenient hookup to the air tool.

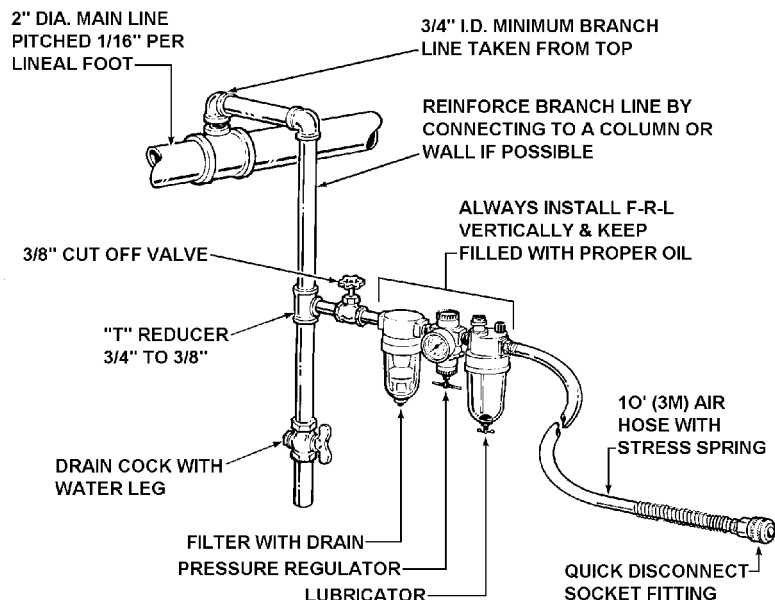

Filter and lubricator bowls are made of polycarbonate material. Do not install where bowls may be exposed to materials incompatible with polycarbonate. Certain oils, solvents, and chemicals or their fumes can weaken these bowls and possibly cause them to burst. Clean only with warm water. A cut-off valve placed ahead of the filter will be useful when cleaning the filter or replenishing the lubricator.

MOISTURE

Moisture is always present in air lines due to condensation within the lines as the air cools. Steps must be taken to remove this moisture and to keep it from the air tool. This is because water tends to wash away lubricants and cause corrosion, sticking and failure of internal parts.

The main line should be pitched so the far end terminates in a water leg. Branch lines are taken from the top of the main, never off the bottom. Every branch should have a water leg at its lowest point, with a drain cock which is drained daily.

If these precautions are taken and water is still present, an after cooler and a moisture separator are required between the compressor and the air receiver tank. A large air line separator can be installed in the air tool line, but precautions must be taken to insure that it will be drained daily, before the air tool is operated.

Water in air lines is a constant threat to the proper operation of air tools. Even near freezing operating conditions, a good refrigerant type dryer is essential. A good dryer will remove 95% or more of water right at the compressor. The remaining moisture is removed at the water leg in the piping system or in the filter, Signode Part No. 173111. Additional information is available in the Signode publication, "Air Supply Manual" p. 25, E-186038. If you have any questions, contact your local Signode Representative.

LUBRICATION

The air motor must be properly lubricated. This is achieved by keeping the air line lubricator filled with oil and correctly adjusted. Without proper lubrication, the motor will become sticky and the tool will give low and erratic tension.

Install the lubricator as close to the air tool as possible. The arrow on the lubricator's top surface must point in the direction of air flow.

For proper operation, oil must drop through the lubricator sight glass at a rate of 4 to 10 drops per minute. This rate is to be checked while the air tool is running free. Only 20% of this oil is actually delivered to the tool. The remaining oil drops back into the oil reservoir. The unit is factory set and should require no adjustment. If an adjustment is required, the adjusting screw on top of the lubricator may be turned as marked to reduce or increase the flow of oil.

The correct grade of oil must be used in the lubricator; too heavy an oil will not provide sufficient lubrication and will cause sticking and sluggish operation of the air tool. Recommended oils are any good grade of rust and oxidation inhibiting oil with a viscosity of 80-120 S.U.S. at 100 degrees Fahrenheit. (0.15 to 0.25 cm² /sec. at 38 degrees Celsius), such as:

Non Fluid Oil Co., grade #LS-1236
Signode oil - Part No. 008556

If necessary, use SAE #5 or SAE #10, non-detergent, cut 1:1 with kerosene. Some oils contain anti-wear additives which may disable the air motor. Be certain to use recommended oil.

Several drops of lubricator oil added to the inlet of the air motor or into the air line each day will help insure good operation. A noticeable reduction of air motor performance can usually be corrected by squirting a few drops of oil into the air line.

AIR CONSUMPTION

Air consumption in cubic feet per minute (cfm) for the PRHM-34 can be calculated as follows: $cfm = (a) \times (b) \times (0.23)$

a = Number of straps applied per minute.

b = Number of seconds air motor is on per strap during tensioning, from start to deceleration to stall.

0.23 = PRHM-34 efficiency ratio.

Example calculation:

Peak strapping load is 4 straps/minute, so a = 4. Air motor is on 5 seconds/strap, so b = 5. PRHM-34 efficiency ratio is 0.23.

$(a) \times (b) \times (0.23) = 4 \times 5 \times 0.23 = 4.6$ cubic ft/min.

$4 \times 5 \times 0.39 = 7.8$ cubic meters/hr. (7.8M³/hr.)

Air pressure is assumed to be 90 psig (6.2 bar) with the recommended size and length of air hose. Volume of air at room temperature and sea level pressure, or so-called 'free air' conditions. For more detailed information about air supply systems, refer to Signode manual Part No. 186038.

PNEUMATIC INFORMATION, Continued

AIR PRESSURE vs. STRAP TENSION

Strap tension is controlled by air pressure. Use the proper air line piping and lubrication as specified in this manual. Your air pressure gauge must be accurate, therefore, confirm its accuracy by comparing it to a calibrated master gauge.

WARNING

Strap breakage hazard. 3/4" (19mm) strap can break during tensioning if inlet air pressure to the tool exceeds 70 psig. Strap breakage can result in serious personal injury. Maximum operating pressure is 90 psig.

COLD WEATHER OPERATION

If a tool does not operate satisfactorily in freezing temperatures, certain steps can correct the problem. The following steps can be taken to improve cold weather operation of the tool:

- a. An air line dryer adjacent to the compressor.
- b. Use lubricant recommended by Signode. Signode has tested the use of anti-freezes, none work well in air tools; the tool will gum up when anti-freezes are introduced and will not function properly. The best lubricant for freezing weather is the 1 to 1 oil and kerosene combination.
- c. If possible, run the air supply line to a indoor located Filter-Regulator-Lubricator or relocate the F-L-R to a warmer operating area.

TOOL MAINTENANCE, CLEANING & LUBRICATION

Clean and apply a light weight machine oil to all moving parts on a weekly basis. Clean the feedwheel daily with a wire brush. Refer to the Pneumatic Instructions for lubricant recommendations with regard to the air motor.

WARNING

Inspect all parts daily and replace them if they are worn or broken. Failure to do this can affect a product's operation and could result in serious personal injury.

SET-UP FOR TOOL OPERATION

STRAP TENSION

The PRHM-34 has been factory adjusted to draw at least 1400 lbs. (6230N) of tension at 90 psig (6.2 bar). A minimum of 70 psig (4.8 bar) is required to ensure that the tool will seal properly.

Strap tension is accurately controlled by air pressure to the tool and the setting of the adjusting screw. Use proper air line piping and lubricant as specified in this manual. Air pressure gauge must be accurate. Confirm calibration at tool gauge by comparing it to a master gauge.

Adjust strap tension as follows:

1. Make sure the air pressure is set between 70 and 90 psig (4.8 - 6.2 bar).
2. Loosen the lock nut and turn the adjusting screw clockwise to decrease tension and counterclockwise to increase tension.

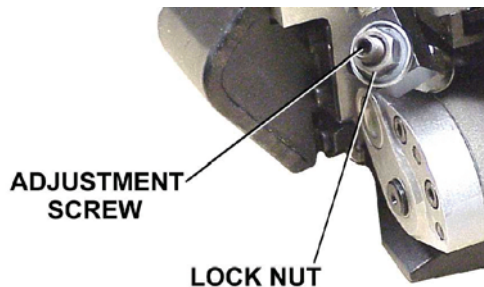

! WARNING

Strap breakage hazard. Increasing the tension can result in strap breakage and could cause personal injury.

Never remove the adjusting screw from the tool with the air connected. The screw could become a flying projectile.

OPERATION POSITIONS

To work effectively, the PRHM-34 must be properly oriented to the package. This installation includes, in some cases, proper suspension of the tool over the container to be strapped and the proper placement of a strapping dispenser to provide a continuous easy supply of strapping for the application.

A spring loaded detent in the tool hanger allows the tool to be rotated into several different operating positions shown below.

To adjust the tool position, apply a steady amount of force to the end of the hanger bracket. The spring lock will then release allowing the bracket to be moved to the next position.

Three of the PRHM's most popular operating positions are shown below:

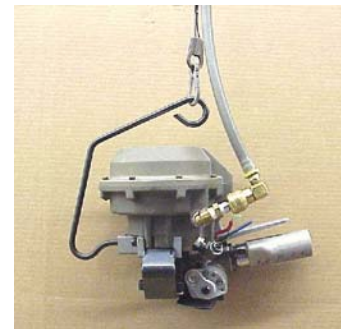

TOP SEALING



VERTICAL SEALING



HORIZONTAL SEALING

OPERATING INSTRUCTIONS

WARNING

- Wear safety glasses which conform to ANSI Standard Z87.1 or EN 166.
- Stand to one side of the strap while tensioning. Make sure all bystanders are clear before proceeding.
- Failure to follow the above could result in serious personal injury.

1. STRAP AND SEAL LOADING

Refer to the Specifications section on page 4 to make sure the correct strap and seal have been chosen. Insert the lead end of the strap into the seal.

Pass the strap over the top of the package then bring the lead end around and up and rethread it into the seal. This will result in creating a TOP STRAP and a BOTTOM STRAP. They will be referred to later in these instructions.

Bend a minimum of 2 1/2" (64mm) of the lead end of the BOTTOM STRAP back beneath the seal to maintain the loop. Refer to Figure 1 to make sure the loop has been properly formed. Hold the BOTTOM STRAP and pull back on the TOP STRAP to draw the loop loosely around the package. A gentle upward bend on the TOP STRAP will hold the loop in place while the PRHM-34 tool is being positioned.

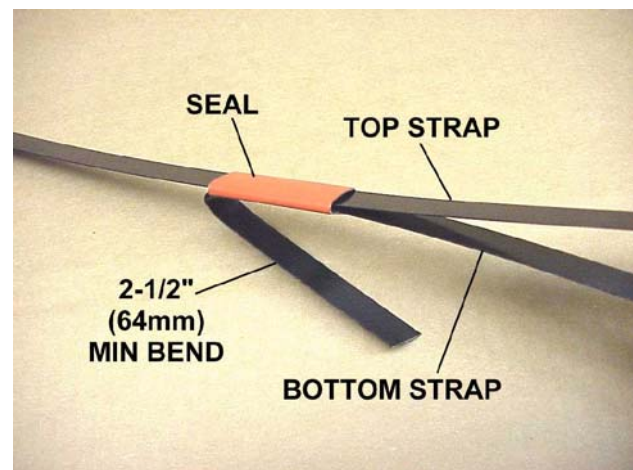

2. POSITIONING THE TOOL

Squeeze the handle and the air motor together to create an opening between the feedwheel and the tensioner foot. Grasp the TOP STRAP and insert it sideways into the tool between the feedwheel and the tensioner foot. Make sure the strap end is in contact with the inside surface of the tensioner foot. When the TOP STRAP is properly loaded, the sealing mechanism will be in line with the seal.

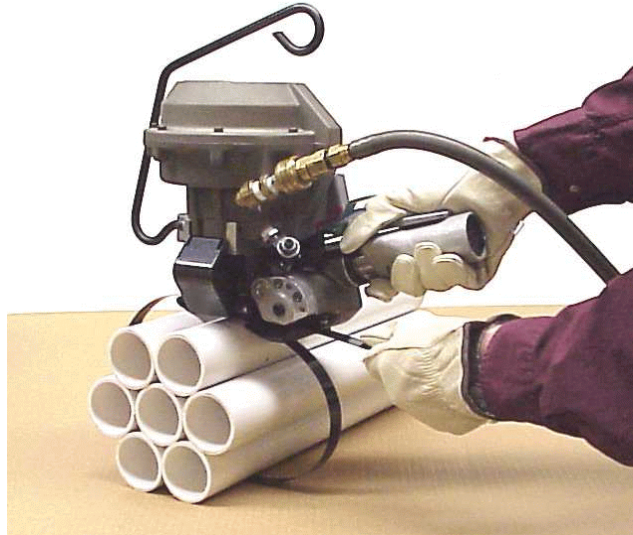
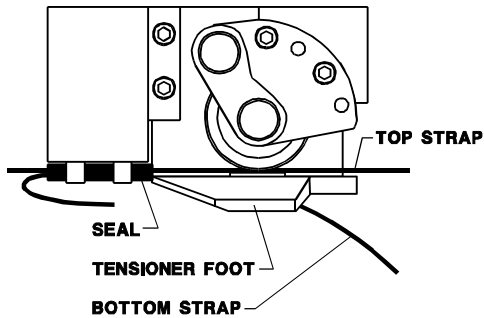

Push the tool forward until the nose of the tensioner foot contacts the end of the seal.

3. REMOVING THE STRAP SLACK

Pull back on the TOP STRAP to eliminate additional slack strap around the package.

NOTE: Before continuing, make sure the TOP STRAP and the seal are still in position, as described above. Note that the BOTTOM STRAP will be positioned in the channel on the bottom surface of the breaker foot. This too, is necessary to maintain strap alignment during tension.

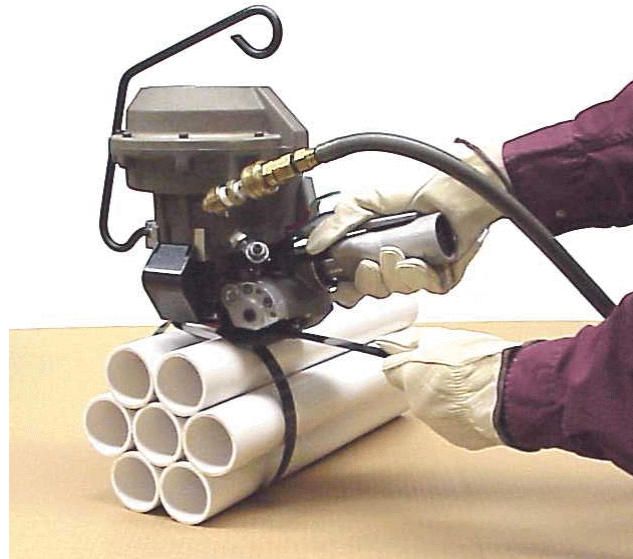

Continued . . .

OPERATING INSTRUCTIONS, Continued

4. TENSIONING THE STRAP

While standing to one side of the strap, press the tension lever (Green lever) all the way down. The catch link will then engage the tension lever holding it in the down position.

The strap will tension around the package until the proper tension level has been reached, at which time the air motor will stall. Refer to page 9 for detailed information about adjusting strap tension.

NOTE: *If strap alignment is unsatisfactory and it becomes necessary to shut off the tool during the tensioning portion of the cycle, push the catch link (Red lever) over to the left, releasing the tension lever. Cut off the strap and apply a new strap in a more favorable position.*

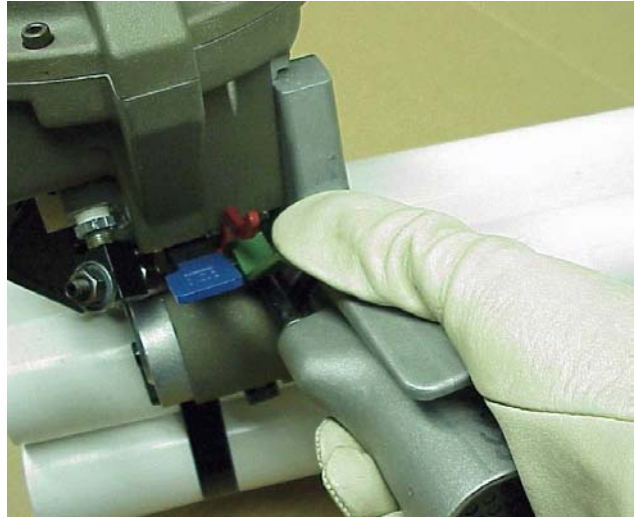

5. FORMING THE STRAP JOINT

Press down and hold the sealer lever (Blue lever). Air will be then routed to the top of the cylinder enabling the sealer mechanism to notch the seal/strap and cut-off the TOP STRAP. The tool will disengage from the seal and strapped package leaving the cut off end of the strap clamped under the feedwheel.

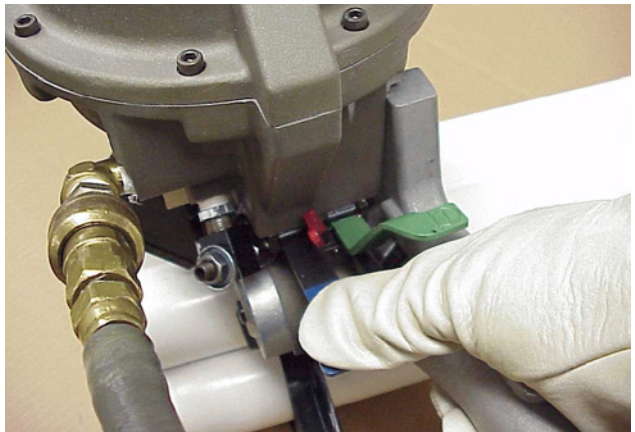

6. TOOL REMOVAL & JOINT INSPECTION

Squeeze the handle and the air motor together to release the cut off strap end. Lift the PRHM-34 tool from the tie and closely inspect the joint to make sure the tool has properly notched the seal. Refer to Sealing Operation on the following page for details regarding an acceptably notched joint.

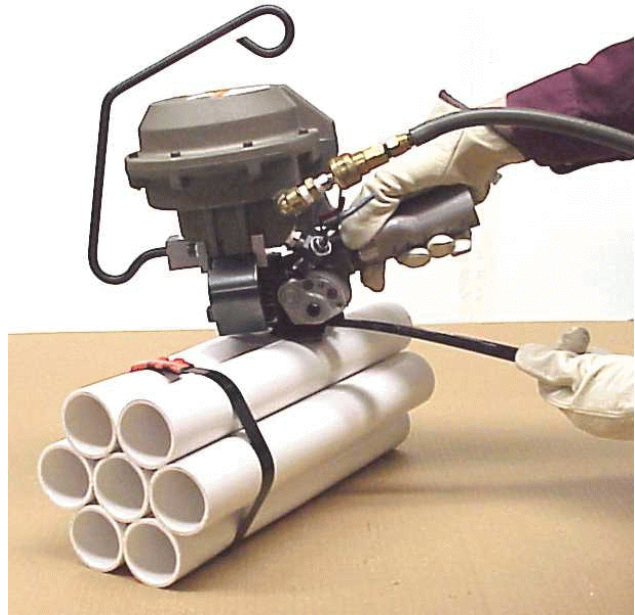

WARNING

This tool is a double reverse notch-joint sealers. Each notch-joint must be inspected to make certain it has four (4) good notches. A properly formed notch-joint will appear as shown in the illustration. If the notch-joint does not appear as shown, then the operator must proceed as follows.

1. Make certain that the tool's operating instructions are being followed before applying another strap.
2. Cut the strap off and apply a new strap and seal.
3. An improper formed seal which does not have four (4) good notches, could result in strap separation. Before moving any package be certain that the seal is formed as shown. Inspect the joint to make certain it appears as shown in the illustration. If not, remove the broken strap and check the tool for worn or broken parts. Repair the tool for worn or broken parts. Repair the tool before applying another strap.

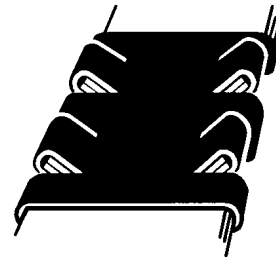

PART REMOVAL, REPLACEMENT & TOOL ADJUSTMENTS

The following procedure fully describes the disassembly of the PRHM-34. The instructions can be reversed to assemble the tool. Please note that areas of the tool which require specific adjustments for reassembly will be explained as well.

The disassembly instructions begin at a logical point for fully disassembling the tool, yet this is not always necessary. Some disassembly procedures may be appropriately skipped in order to avoid unnecessary labor.

Use the following instructions to disassemble the PRHM-34:

STEP 1 - FEEDWHEEL (For additional part information see pages 22 & 23)

1. To replace the feedwheel, remove the two socket head cap screws which secure the outer link. Remove the outer link from the gear housing. Slide the feedwheel off the feedwheel shaft. The counterbore face of the feedwheel must face the outer link in order to match up with the flange bushing in the outer link.

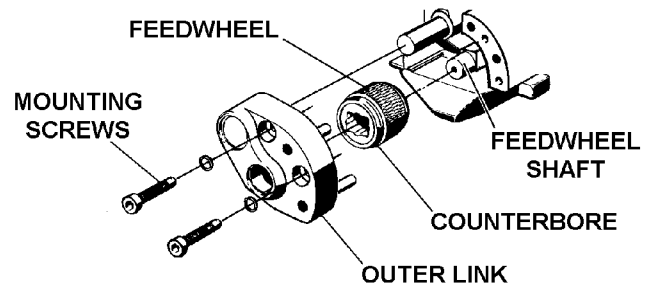

2. Replace the feedwheel in the same manner in which it was removed. Feedwheel clearance should be checked after replacing any parts associated with the tensioning system. This clearance should be maintained to prevent the feedwheel from touching the wear pad and encouraging early failure of these parts.

Feedwheel clearance can be set as follows:

- a. Loosen the lock nut which secures the hex head adjustment screw which controls feedwheel clearance.
- b. Feedwheel clearance should be adjusted to .002"-.007" (0.05mm-0.17mm) clearance. Place an appropriate feeler gauge between the feedwheel and the wear plug, turn the hex head screw until the proper feedwheel clearance has been reached.

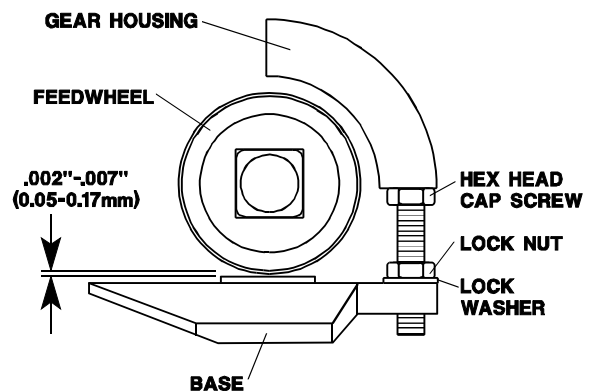

- c. When the clearance has been set, secure the hex head screw with the lock nut. Recheck feedwheel clearance and adjust if necessary.

PART REMOVAL, REPLACEMENT & TOOL ADJUSTMENTS, Continued

STEP 2 - MOTOR/HOUSING ASSEMBLY (For additional part information see pages 26 & 27)

1. To remove the motor/gear housing assembly, first, disconnect the air line tubing at the adjustment block. Push the motor/gear housing off the pivot shaft which goes through the tensioner foot.

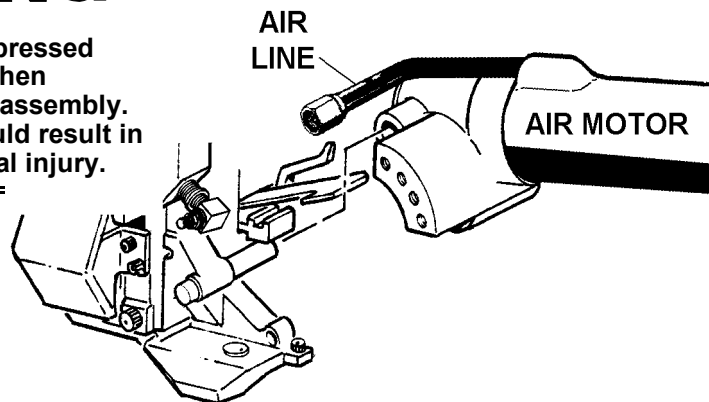
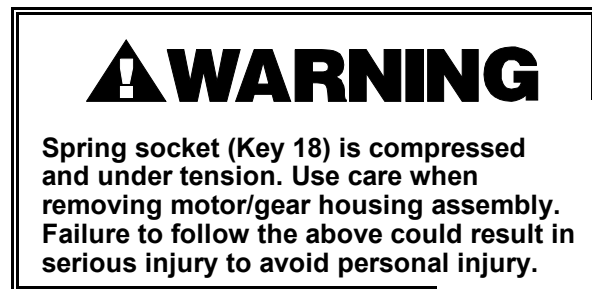

Note that resistance may occur due to the spring loaded spring socket imbedded in the handle which pushes on the gear housing. This resistance may be overcome by moving the motor/gear housing up and down against the spring socket while pushing away from the tensioner foot.

STEP 3 - GEAR HOUSING (For additional part information see pages 28 & 29)

1. Remove the air motor from the gear housing (84) by clamping the gear housing in a vise, and using a 44.5mm (1-3/4 inch) wrench, loosen the lock nut (301) and remove the motor by turning clockwise (left hand thread).
2. Remove the worm (91), bearing (100), and bearing sleeve (82). Note that the bearing is pressed into the bearing sleeve with the heavy race away from the worm.
3. Remove the two cap screws (95) that attach the bearing cover (87) to the gear housing and carefully pry off. Take out the feedwheel shaft (85) and worm wheel (86). Note that when reinstalled, the small diameter hub on the worm wheel must be facing the bearing cover. Inspect feedwheel shaft and seal (105) for damage. Parts and housing must be free of metallic particles. Clean and regrease using K-55 non-fluid oil. Fill the gear housing 1/3 to 1/2 full.

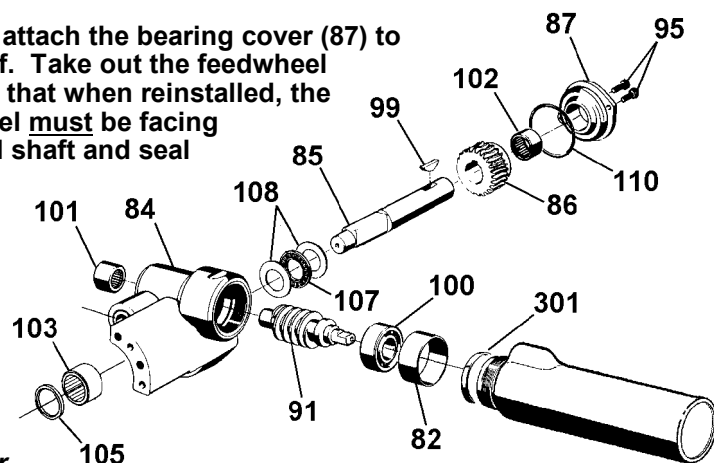

NOTE: If replacing an older PRHM motor (423700 or 306710) with the newer style motor (424160) the Air Motor Conversion Kit, Part No. 424195 must be used. See page 37 for additional details.

PART REMOVAL, REPLACEMENT & TOOL ADJUSTMENTS, Continued

STEP 4 - TOOL HANGER & GUARD ASSEMBLY

(For additional part information see pages 24 & 25)

1. With the hanger (63) detented to one side, turn the tool over and place it on its cover. Loosen the four cap screws (61) holding the guard assembly (78) and remove the two large cap screws (66) that attach the hanger mount (60) to the cylinder.
2. Remove the Truarc ring (77) and remove the sleeve (80), spring (71), and clutch (64). Remove the Woodruff key (81) before removing the detent (65). Inspect the hanger, key, and teeth on the clutch and detent. Replace as necessary using a liberal amount of Molith #1 or Lubriplate #3000W grease when reassembling.

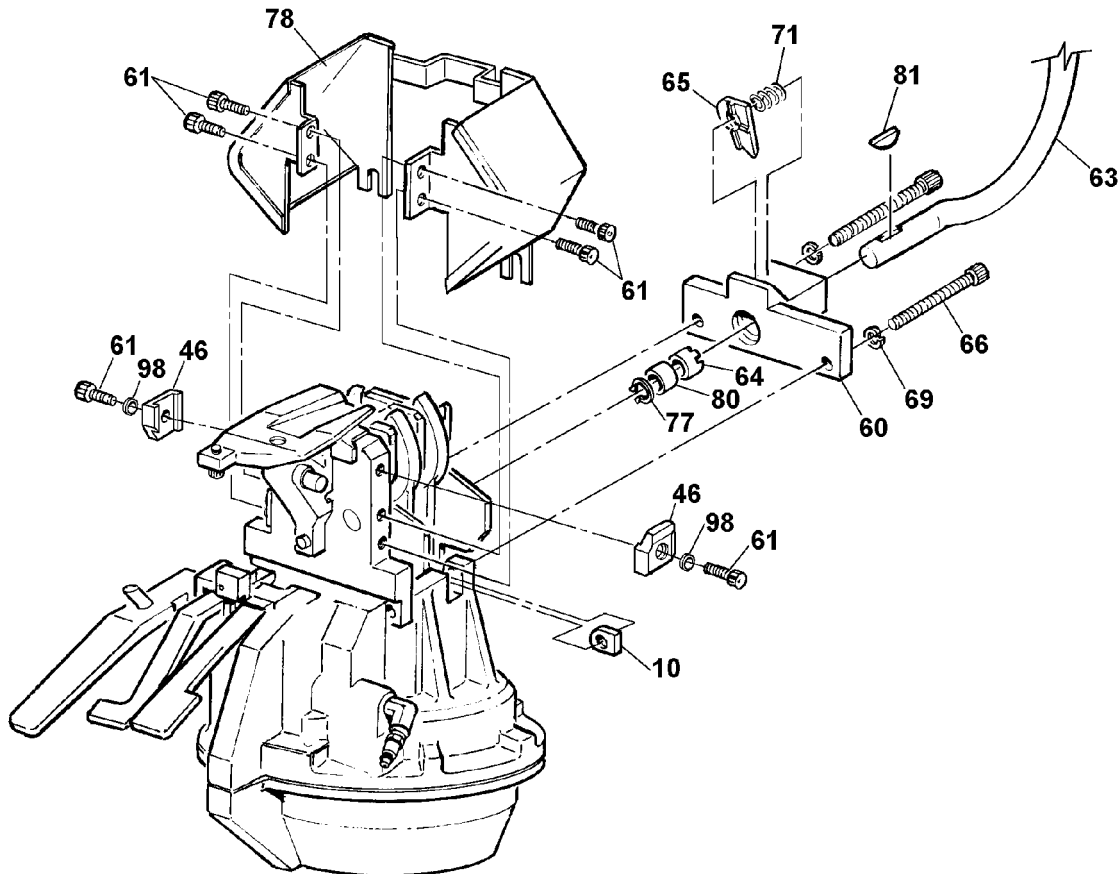

3. When reinstalling the hanger to the cylinder, slide the whole mechanism toward the Truarc putting a little pressure on the spring to make sure the clutch and key stay engaged. When putting the screws into the cylinder bottom be sure the jaw guides are positioned properly.
4. Install the two cap screws tighten evenly. Install the four guard assembly mounting screws. Check the detenting action by rotating the hanger to its four positions.
5. In order to completely remove the guard assembly, remove the four socket head cap screws (61) which secure the guard. Loosen and back out approximately 3mm (1/8") the two large socket head cap screws which attach the hanger assembly to the tool. Continue to remove the two socket head cap screws, lock washers (98) and guides (46) from the tool. Lift the guard assembly straight up.

PART REMOVAL, REPLACEMENT & TOOL ADJUSTMENTS, Continued

STEP 5 - SEALER MECHANISM (For additional part information see pages 22, 23, 24, 25)

1. With the hanger and guard assembly removed from the tool, turn the tool upright and remove the eight cap screws (19) and washers (98) from the cover (9). Remove the cover and note the position of the diaphragm (17) with the number "20" centered at the rear of the tool. This positioning matches the screw holes in the cover and cylinder bottom with the cutouts in the diaphragm.

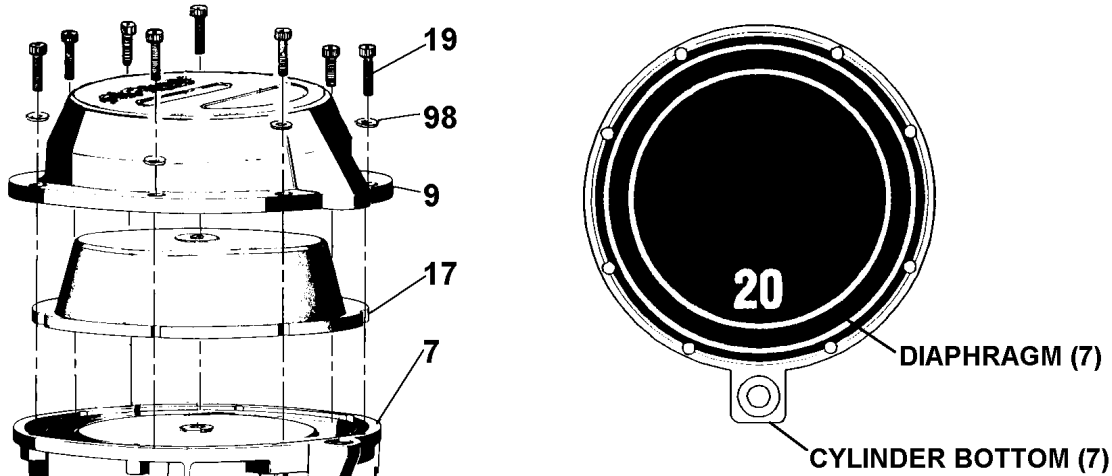

2. Grip the cylinder bottom (7) and loosen the cap screw (21) that attaches the piston (8) to the piston rod (39). Grip the piston firmly with one hand while removing the cap screw because the two large springs (29,30) are compressed.

⚠ WARNING

Compression springs (Keys 29 & 30) are compressed and under tension. Use care when removing the piston (Key 8). Failure to follow the above could result in serious injury to avoid personal injury.

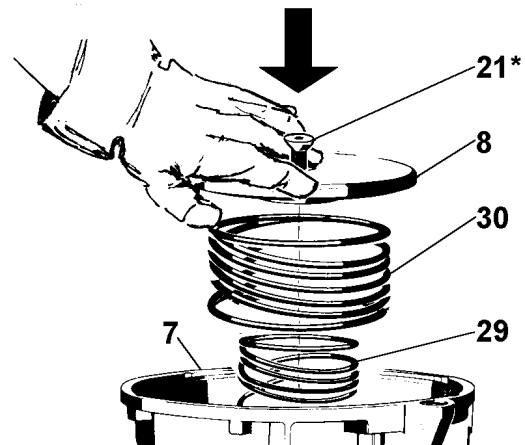

3. Once the piston and springs have been removed, the sealer mechanism along with the tensioner foot, support plate, and cutter will drop out from the bottom of cylinder. The tensioner foot and cutter assembly will also separate from the sealer assembly at this time. Set these aside for later inspection.

* Secure with Loctite #242.

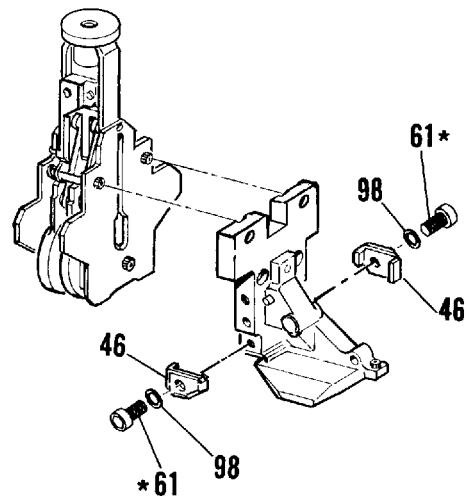

PART REMOVAL, REPLACEMENT & TOOL ADJUSTMENTS, Continued

STEP 6 - PNEUMATIC VALVES AND LEVER ASSEMBLY

(For additional part information see pages 22 & 23)

1. Remove the two cap screws (23) that attach the support block (11) and operating levers (12,13) to the cylinder bottom. The catch link pin (15) and lever pin (14) should be lubricated with oil or grease and the small compression spring (26) under the catch link should not be bent. Replace and lubricate if necessary.
2. Remove the valve stems (2,4). Small pliers may be needed to pull out the tension valve stem. Using a hook or bent wire pull the valve sleeves (1,3) out. Check condition of o-rings (35,37,38,118) on inner and outer diameters of both sleeves and check rubber balls (31,32) for wear. Replace as necessary.

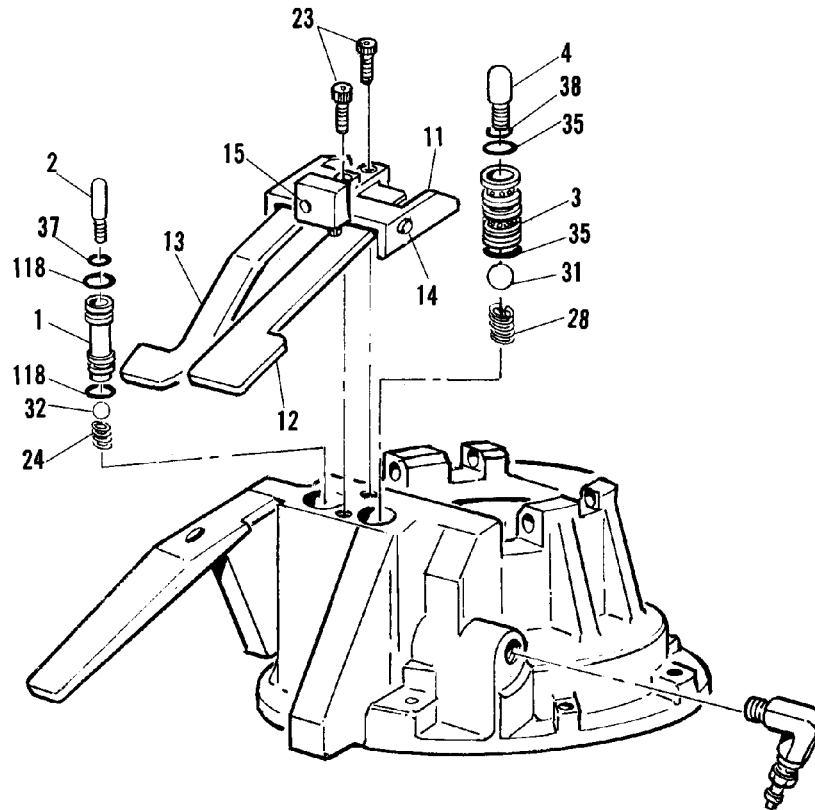

3. Before reinstalling the sealer valve sleeve, be sure that the large compression spring (28) is pushed down and seated all the way in the hole. Failure to do this will cause the spring to become skewed and the ball will not seal.
4. Liberally grease o-rings with Lubriplate high temperature grease. When installing valve sleeves, slowly push them into the holes so the o-rings will not be cut by the air passages in the housing.
5. This completes the disassembly and repair of the tool. Reassembly should be done in reverse order. Check the parts list section of this manual for replacement part numbers and lubrication and Loctite notes.

PARTS LIST, PRESSURE CYLINDER

<u>KEY</u>	<u>QTY.</u>	<u>PART NO.</u>	<u>DESCRIPTION</u>	
1	1	306650	Valve sleeve (tension)	
2	1	306651	Valve stem (tension)	
3	1	306652	Valve sleeve (seal)	
4	1	306653	Valve stem (seal)	
5	1	306657	Catch link	
6	1	306658	Screen	
7	1	306671	Cylinder bottom	
8	1	306672	Piston	
9	1	306673	Cylinder cover	
10	2	306677	Jaw guide	
11	1	306679	Lever support	
12	1	306680	Valve lever (sealer)	
13	1	306681	Valve lever (tension)	
14	1	306682	Lever pin	
15	1	306683	Catch pin	
16	1	306684	Handle	
17	<u>1</u>	<u>306685</u>	<u>Diaphragm</u>	
18	1	306701	Spring socket	
19	10	165392	SHCS, M5 x 30	
20	2	010037	SHCS, M6 x 20	
21	1	306729	FHSCS, M8 x 30	
23	2	256970	SHCS, M4 x 25	
24	1	306776	Compression spring, Lee #LC-026D-3	
25	1	306777	Compression spring, Lee #LC-045D-19	
26	1	306778	Compression spring, Lee #LC-016A-4	
27	1	306779	Compression spring, Lee #LC-022D-6	
28	1	306741	Compression spring, Lee #LC-042G-5	
29	1	306721	Compression spring, inner	
30	1	306722	Compression spring, outer	
31	1	306733	Rubber ball, 5/8" Dia.	
32	1	306734	Rubber ball, 3/8" Dia.	
33	1	008478	Reducing bushing, 3/8 x 1/4"	
34	1	020704	Hansen plug, 1/4-18	
35	2	022789	O ring, #2-016	
36	1	008798	Tag	
37	1	004164	O ring, #2-011	† Install using Teflon pipe tape.
38	2	097529	O ring, #2-111	* Secure with Loctite #242.
39	1	306665	Piston rod	** Lubricate with Molith #2 or
41	1	016148	Pipe nipple	
42	1	306660	Wear plate	Lubriplate #3000W grease.
43	2	150589	BHCS, M3 x 8	
44	1	306707	Nameplate	
45	1	286385	Warning sign	
98	14	187415	Split lockwasher, 5mm	
109	1	422693	Adjustment block	
112	1	059918	Hex nut, 5/16-18	
113	1	171655	Nylon lockwasher	
114	1	171661	Steel collar	
115	1	024714	Screw	
117	1	015219	Pipe plug, 1/8"	
118	2	092772	O ring, #2-014	
120	1	004190	Street elbow, 3/8	
123	1	286373	3-Icon information sign	
125	1	250907	Reducing Bushing, 1/8 x 1/4	

- When ordering parts, please show tool model, part number and description.
- Wearing parts are usually limited to those underlined and should be stocked.
- Standard hardware may be obtained at any local hardware supply.

NOTES:

Lubricate valve parts with Lubriplate grease.

To align holes properly, assemble Diaphragm (Key 17) with the numeral "20" pointing to the rear of the tool as shown.

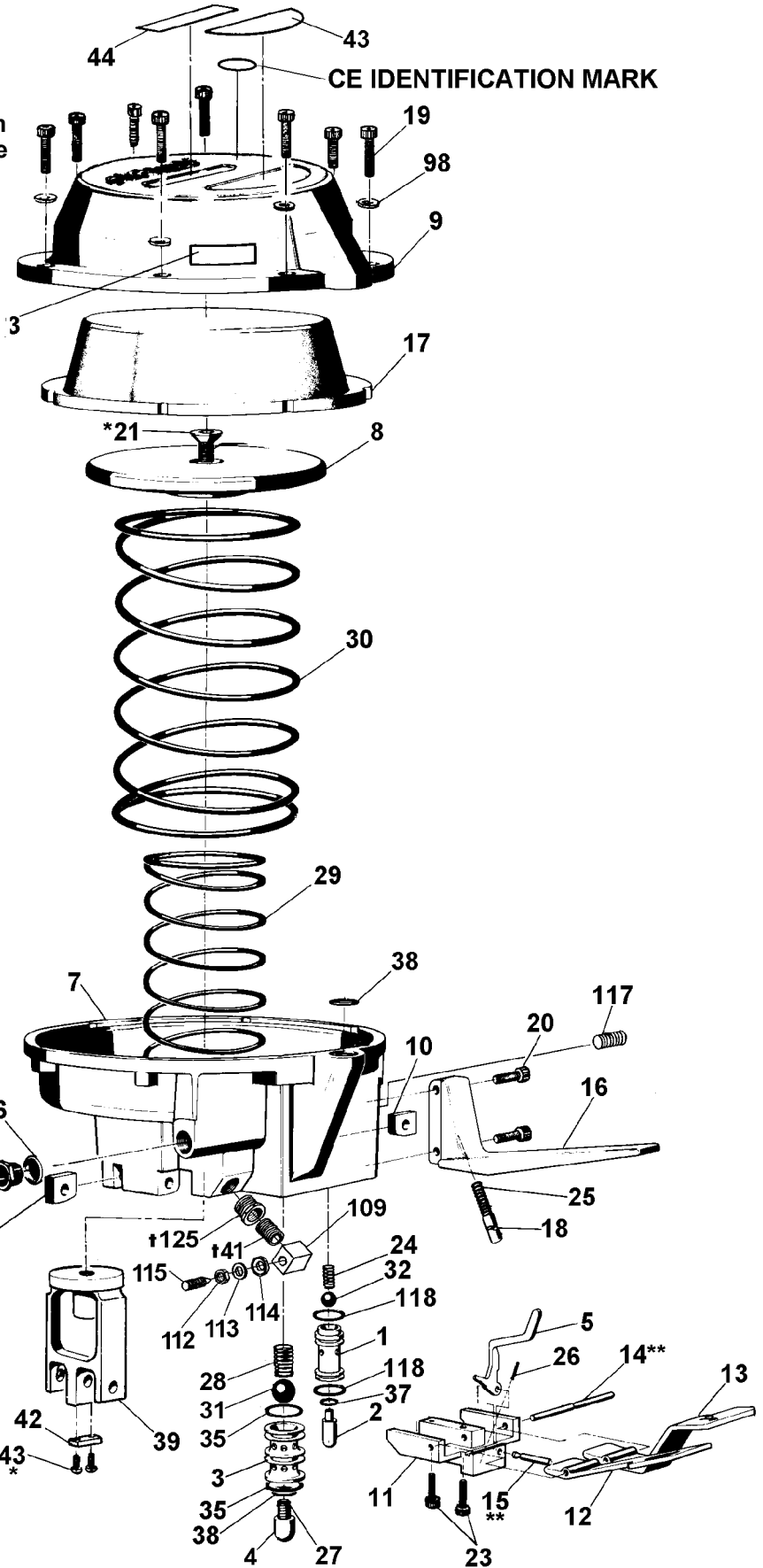
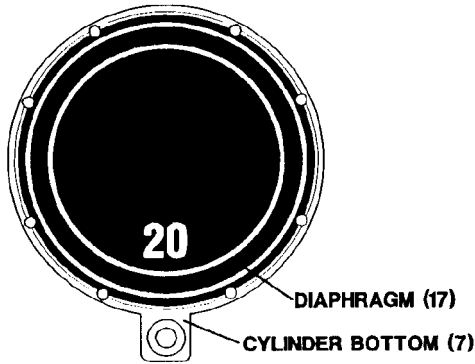

! WARNING

Compression springs Keys 25, 26, 29, 30) are compressed under tension.

Use care when removing the piston (Key 8) to avoid personal injury.

Inspect all parts daily and replace them if they are worn or broken. Failure to do this can affect a product's operation and could result in serious personal injury.

PARTS LIST, JAW STACK

<u>KEY</u>	<u>QTY.</u>	<u>PART NO.</u>	<u>DESCRIPTION</u>
40	2	010036	FHSCS, M6 x 16
46	2	306654	Guide
47	4	306659	<u>Jaw</u>
48	4	306661	<u>Notcher</u>
49	2	306662	<u>Jaw pin</u>
50	4	306663	<u>Jaw link</u>
51	4	306664	<u>Link pin</u>
52	1	306666	<u>Rod pin</u>
53	1	306667	<u>Side plate, rear</u>
54	2	306668	Spreader
55	2	306764	Spacer sleeve
56	1	306670	<u>Side plate, front</u>
57	1	306674	<u>Cutter</u>
58	1	306675	Cutter lever
59	1	306676	Support plate
60	1	306678	Hanger mount
61	6	010028	<u>SHCS, M5 x 12</u>
62	2	424042	Bushing
63	1	306698	Hanger
64	1	306702	Clutch
65	1	306703	Detent
66	2	186983	SHCS, M8 x 60
67	1	306738	<u>Flat head socket cap screw, M5 x 50, partial thread</u>
68	1	306755	Lock nut, M5, poly insert
69	2	162381	Split lock washer, 8mm
71	1	306732	Compression spring, Lee #LC-067GH-1
72	2	424041	Serrated lock washer, 6mm
77	1	086190	Truarc, Klipring #5304-37
78	1	423286	Guard assembly
80	1	306706	Hanger sleeve
81	1	007334	Woodruff key
97	2	169440	Hex nut, M5
98	13	187415	Split lockwasher, 5mm
122	4	171689	<u>SHCS, M5 x 18</u>
124	1	306737	Dowel pin, 6 x 34mm

- When ordering parts, please show tool model, part number and description.
- Wearing parts are usually limited to those underlined and should be stocked.
- Standard hardware may be obtained at any local hardware supply.

⚠ WARNING

Inspect all parts daily and replace them if they are worn or broken. Failure to do this can affect a product's operation and could result in serious personal injury.

* Secure with Loctite #242.

** Secure with Loctite #272.

† Press fit.

NOTE: Lubricate all moving parts with Molith #2 or Lubriplate #3000W grease.

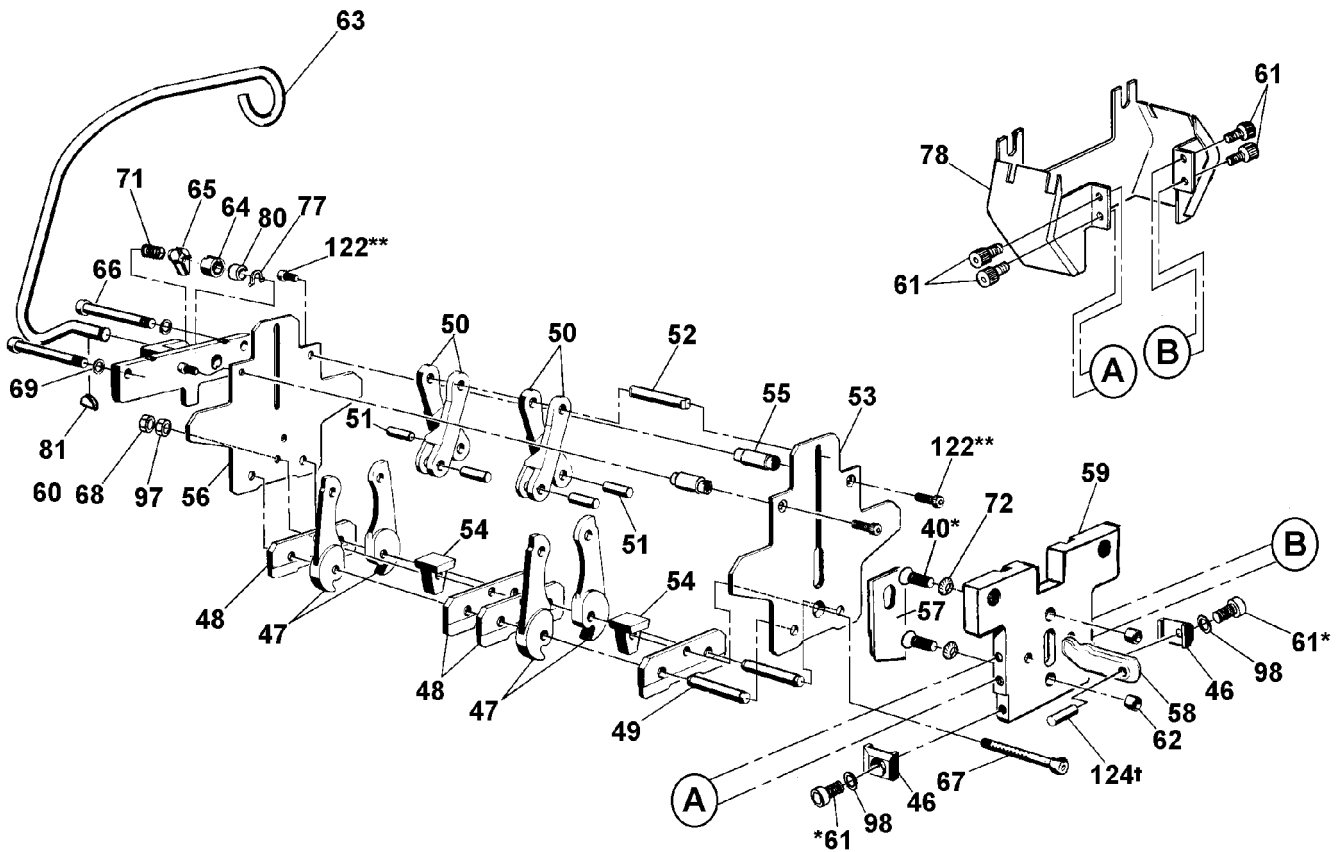

PARTS LIST, TENSIONER FOOT

<u>KEY</u>	<u>QTY.</u>	<u>PART NO.</u>	<u>DESCRIPTION</u>
19	2	165392	SHCS, M5 x 30
70	2	162404	Dowel pin, 6 x 28mm
73	1	422696	<u>Fitting</u>
83	1	306687	<u>Tensioner foot</u>
88	1	423566	<u>Feedwheel</u>
89	1	306694	Pivot shaft
90	1	306695	Outer link
92	1	424271	<u>Air line tubing</u>
93	1	424160	Air motor
94	1	180145	HHCS, M5 x 16
96	1	306728	<u>SHCS, M5 x 6</u>
97	2	169440	Hex nut, M5
98	14	187415	Split lock washer, M5
101	2	306772	Needle bearing, INA-BK1212
106	1	306767	<u>DU flange bearing, FMB# 1217-DU</u>
111	1	306655	<u>Wear plug</u>
116	1	306699	Guide pin

- When ordering parts, please show tool model, part number and description.
- Wearing parts are usually limited to those underlined and should be stocked.
- Standard hardware may be obtained at any local hardware supply.

WARNING

Inspect all parts dally and replace them if they are worn or broken. Failure to do this can affect a product's operation and could result in serious personal injury.

* Secure with Loctite #242.

** Lubricate with Molith #2 or Lubriplate 3000W grease.

NOTES:

1. Press pin in flush with the back surface of the tensioner foot.
2. Install with polished side facing up.
3. Install feedwheel with counterbore facing towards outer link with arrow in direction shown.

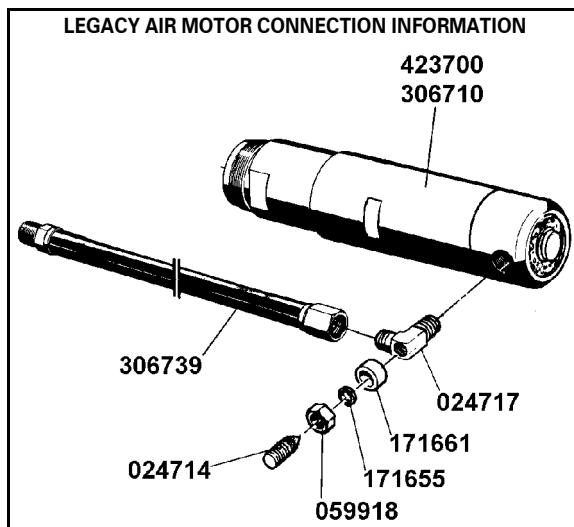
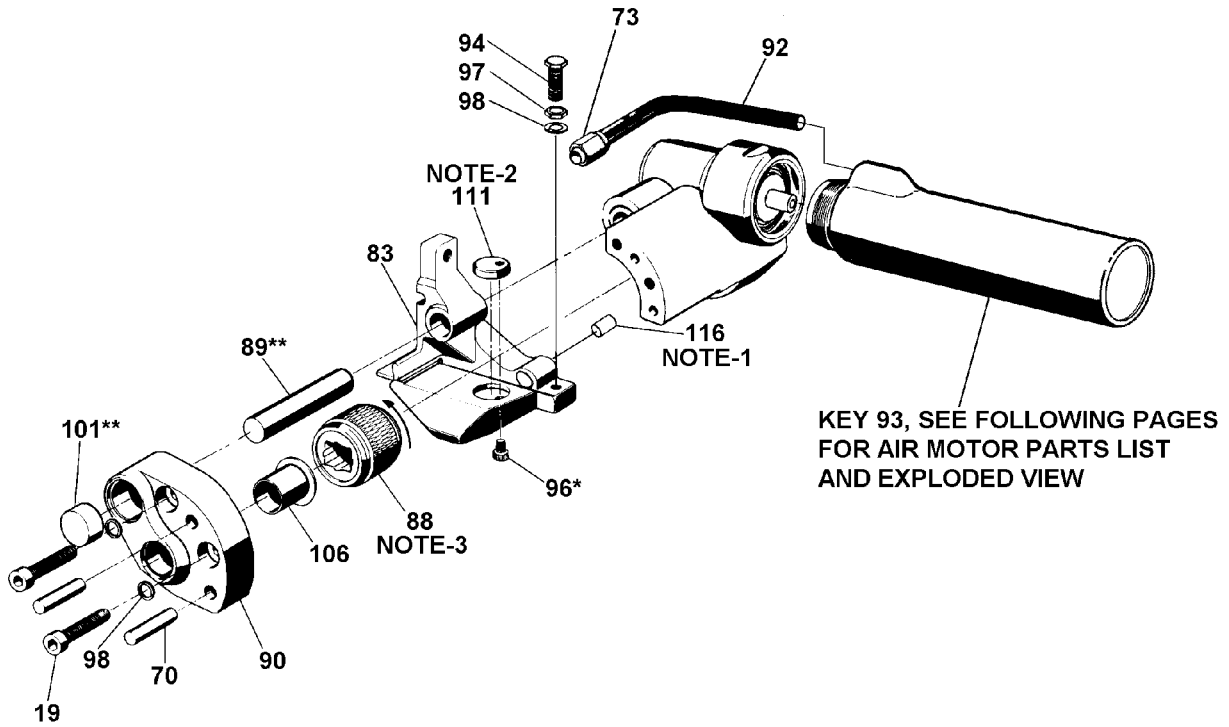

NOTE: If replacing an older PRHM motor (423700 or 306710) with the newer style motor (424160) the Air Motor Conversion Kit, Part No. 424195 must be used. See page 37 for additional details.

PARTS LIST, GEAR HOUSING

<u>KEY</u>	<u>QTY.</u>	<u>PART NO.</u>	<u>DESCRIPTION</u>
82	1	306656	Bearing sleeve
84	1	306689	Gear housing
85	1	306690	Feedwheel shaft
<u>86</u>	<u>1</u>	<u>306691</u>	<u>Worm wheel</u>
87	1	306692	Bearing cover
91	1	306696	Worm
95	2	256747	SHCS, M4 x 16
99	1	000884	Woodruff key, 5 x 7.5 x 18.57
100	1	306771	Ball bearing, INA# 7201BE
101	2	306772	Needle bearing, INA# BK1212
102	1	306770	Needle bearing, INA# BK1712
103	1	306769	Needle bearing, INA# HK1712
104	1	306768	Inner ring, INA# IR12X16X16
105	1	306782	Seal, INA# GR17X23X3
107	1	306766	Thrust needle cage, INA# AXK1730
108	2	306704	Thrust washer, INA# AS1730
110	1	256755	O ring, #2-030

- When ordering parts, please show tool model, part number and description.
- Wearing parts are usually limited to those underlined and should be stocked.
- Standard hardware may be obtained at any local hardware supply.

! WARNING

Inspect all parts daily and replace them if they are worn or broken. Failure to do this can affect a product's operation and could result in serious personal injury.

NOTES

1. Bearing must be installed with the wide shoulder away from the worm gear.
2. Fill the gear housing 1/3 full with Non Fluid Oil #55 (Non Fluid Oil Company or equivalent).
3. Install Key Numbers 103 & 105 in gear housing (Key 84) using Loctite Bearing Mount #609.

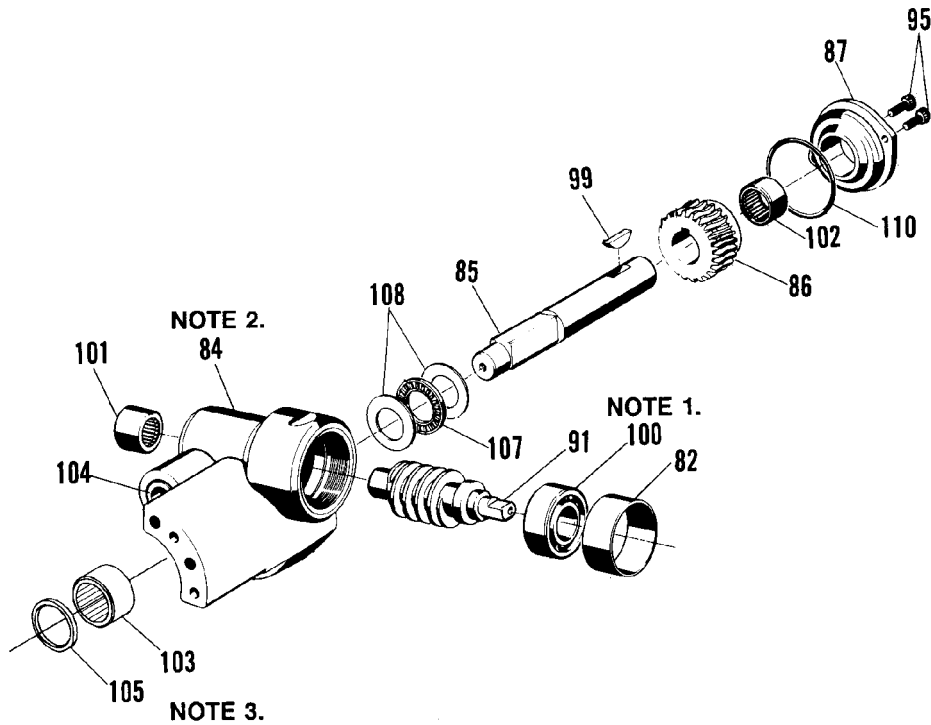

PARTS LIST, AIR MOTOR

Part No. 424150

<u>KEY</u>	<u>QTY.</u>	<u>PART NO.</u>	<u>DESCRIPTION</u>
401	1	424166	Lock nut
402	1	164969	Retaining ring, N5000-118
403	1	023547	Ball bearing
404	1	424159	Idler carrier
405	3	422869	Idler gear
406	1	424153	Motor gear housing
407	1	090079	Lock pin
408	1	422870	Ring gear
410	2	423151	Adapter plate
411	2	014541	Belleville spring washer, B1250-062
412	1	424157	Spacer
413	1	306396	Ball bearing
414	1	424158	Idler carrier
416	3	024605	Idler gear assembly
417	1	024608	Ring gear
418	1	023481	Ball bearing
419	1	424155	Front end plate
420	1	424156	Rotor
421	5	422818	Vane
422	1	422815	Cylinder
423	2	424164	Spring pin, 2.5 x 10
424	1	424154	Back end plate
425	1	424161	Ball bearing
426	2	424172	O-Ring, SAE 125
427	1	424173	Motor housing assembly
428	1	424167	Muffler insert
429	1	424165	Muffler plate
430	1	424162	Truarc, N5000-145
431	1	090065	Lock pin

WARNING

Inspect all parts daily and replace them if they are worn or broken. Failure to do this can affect a product's operation and could result in serious personal injury.

**AIR MOTOR
IDENTIFICATION
PART NUMBER
&
SERIAL NUMBER**

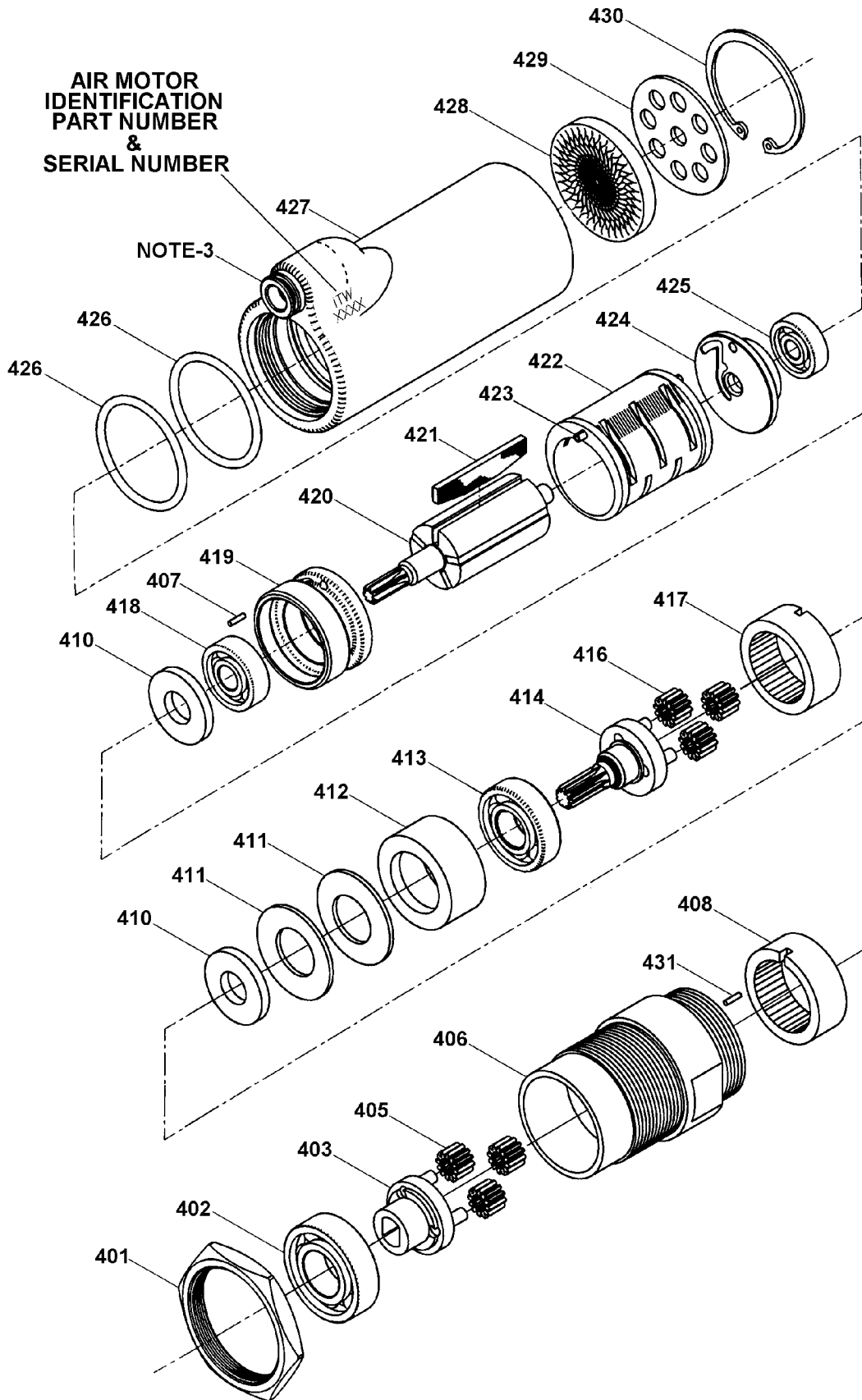

PARTS LIST, AIR MOTOR

NOTE: For repair parts only. No longer available as a new assembly!

Part No. 423700

<u>KEY</u>	<u>QTY.</u>	<u>PART NO.</u>	<u>DESCRIPTION</u>
301	1	422150	LOCK NUT
302	1	264313	BEARING, FAFNIR #9102K-FS118
303	1	422633	GEAR CASE
304	1	422632	SPACER
305	1	422631	SPINDLE
306	3	422637	PLANET GEAR ASSEMBLY
307	1	422628	GEAR
308	3	422627	PIN
309	1	422626	SPACER
310	3	023097	BEARING, FAFNIR #9101K-FS118
311	1	423701	RETAINGIN RING, TRUARC #N5000-106
312	1	422625	GEAR CASE
313	1	422624	SPACER
314	1	422623	SPINDLE
315	2	422622	PLANET ASSEMBLY
316	2	422621	SHAFT
317	1	423702	SPACER
318	1	423703	SPACER
319	1	006554	BEARING, FAFNIR #38KDD
320	1	423704	FRONT END PLATE
321	1	422618	ROTOR
322	5	422617	VANE
323	1	422616	CYLINDER ASSEMBLY
324	1	423705	REAR END PLATE
325	1	250300	BEARING, FAFNIR #36KDD
326	1	423825	SHIELD
327	1	423826	CAP
328	1	423827	HOUSING
329	2	092747	O-RING SAE #18
330	1	092044	O-RING SAE #29
331	1	423828	CAP
332	1	423829	FILLER
333	1	423830	SCREEN
334	1	185765	RETAINING RING, TRUARC #5100-87

- When ordering parts, please show tool model, part number and description.

!WARNING

Inspect all parts daily and replace them if they are worn or broken. Failure to do this can affect a product's operation and could result in serious personal injury.

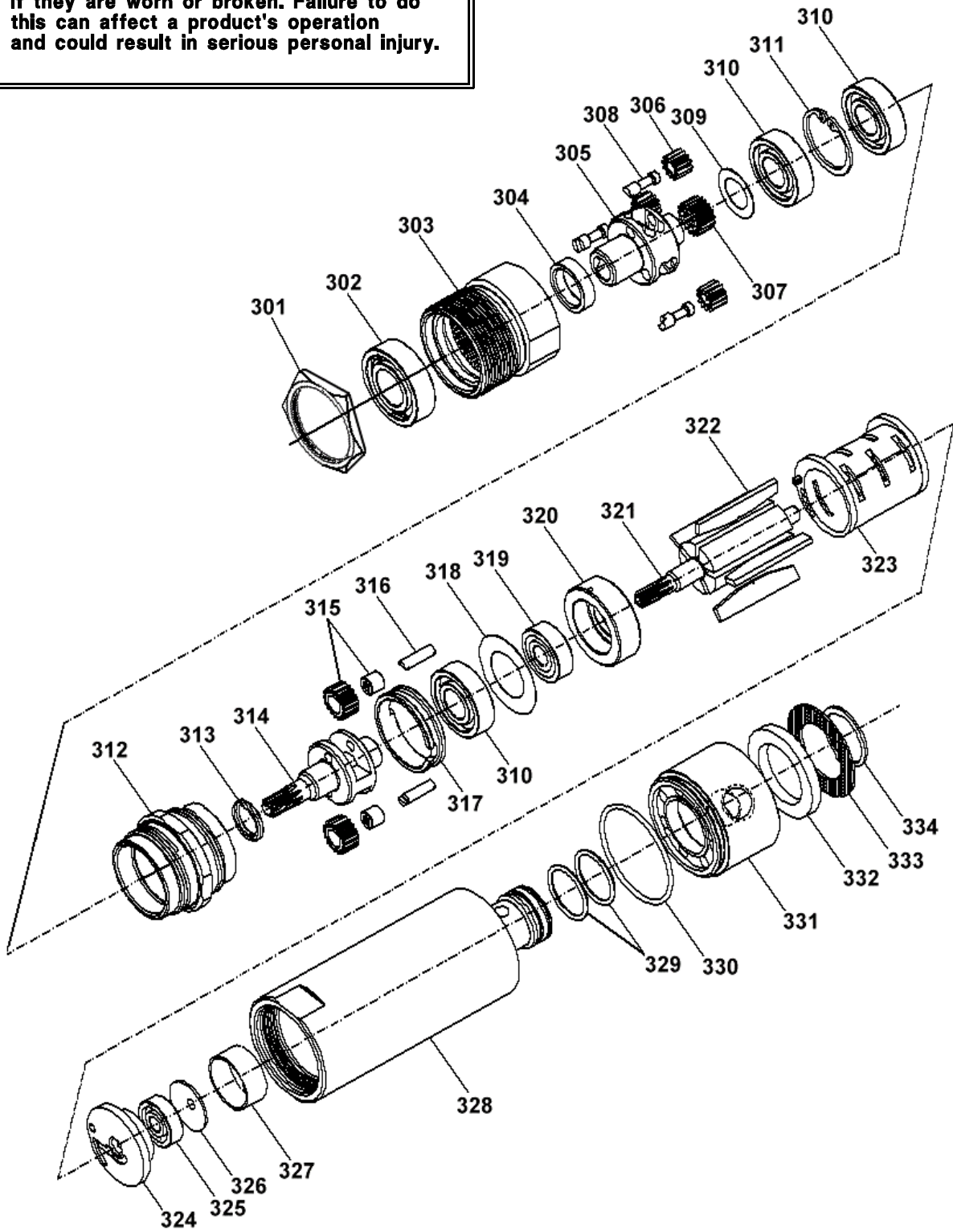

PARTS LIST, AIR MOTOR, MODEL LZB-33A-007-58 (AC)

NOTE: For repair parts only. No longer available as a new assembly!

Part No. 306710 (AC)

<u>KEY</u>	<u>QTY.</u>	<u>PART NO.</u>	<u>DESCRIPTION</u>
<u>201</u>	<u>1</u>	<u>306941</u>	<u>Ball Bearing</u>
<u>202</u>	<u>1</u>	<u>306942</u>	<u>Pin</u>
<u>203</u>	<u>1</u>	<u>306943</u>	<u>Cylinder</u>
<u>204</u>	<u>1</u>	<u>306944</u>	<u>Rotor</u>
<u>205</u>	<u>5</u>	<u>306945</u>	<u>Vane</u>
<u>206</u>	<u>1</u>	<u>306946</u>	<u>Key</u>
<u>207</u>	<u>1</u>	<u>306947</u>	<u>End plate</u>
<u>208</u>	<u>1</u>	<u>306948</u>	<u>Ball bearing</u>
<u>209</u>	<u>1</u>	<u>306949</u>	<u>End plate</u>
<u>210</u>	<u>1</u>	<u>306950</u>	<u>Spacer</u>
<u>211</u>	<u>4</u>	<u>306951</u>	<u>Ball bearing</u>
<u>212</u>	<u>1</u>	<u>306952</u>	<u>Gear rim</u>
<u>213</u>	<u>2</u>	<u>306953</u>	<u>Spring washer</u>
<u>214</u>	<u>1</u>	<u>306711</u>	<u>Gear rim</u>
<u>215</u>	<u>1</u>	<u>306713</u>	<u>Planet shaft</u>
<u>216</u>	<u>2</u>	<u>306954</u>	<u>Axle pin</u>
<u>217</u>	<u>2</u>	<u>306955</u>	<u>Gear wheel assembly (Both must be replaced at same time.)</u>
<u>219</u>	<u>1</u>	<u>306957</u>	<u>Planet shaft</u>
<u>220</u>	<u>2</u>	<u>306958</u>	<u>Axle pin</u>
<u>221</u>	<u>2</u>	<u>306959</u>	<u>Gear wheel assembly (Both must be replaced at same time.)</u>
<u>223</u>	<u>1</u>	<u>306961</u>	<u>Motor housing</u>
<u>224</u>	<u>1</u>	<u>306962</u>	<u>Backhead</u>
<u>225</u>	<u>1</u>	<u>306963</u>	<u>O-Ring</u>
<u>226</u>	<u>2</u>	<u>092747</u>	<u>O-Ring, SAE #2-018</u>
<u>227</u>	<u>1</u>	<u>306964</u>	<u>Circlip</u>
<u>228</u>	<u>1</u>	<u>306965</u>	<u>Silencer</u>
<u>229</u>	<u>1</u>	<u>306966</u>	<u>Filter</u>

- When ordering parts, please show tool model, part number and description.
- Wearing parts are usually limited to those underlined and should be stocked.

The following sub-assemblies may be purchased complete:

Planet shaft assembly (Key numbers 215-217), Part No. 306969.
Rotor assembly (Key numbers 201-209), Part No. 306970.
Planet shaft assembly (Key numbers 219-221), Part No. 422089.

!WARNING

Inspect all parts daily and replace them if they are worn or broken. Failure to do this can affect a product's operation and could result in serious personal injury.

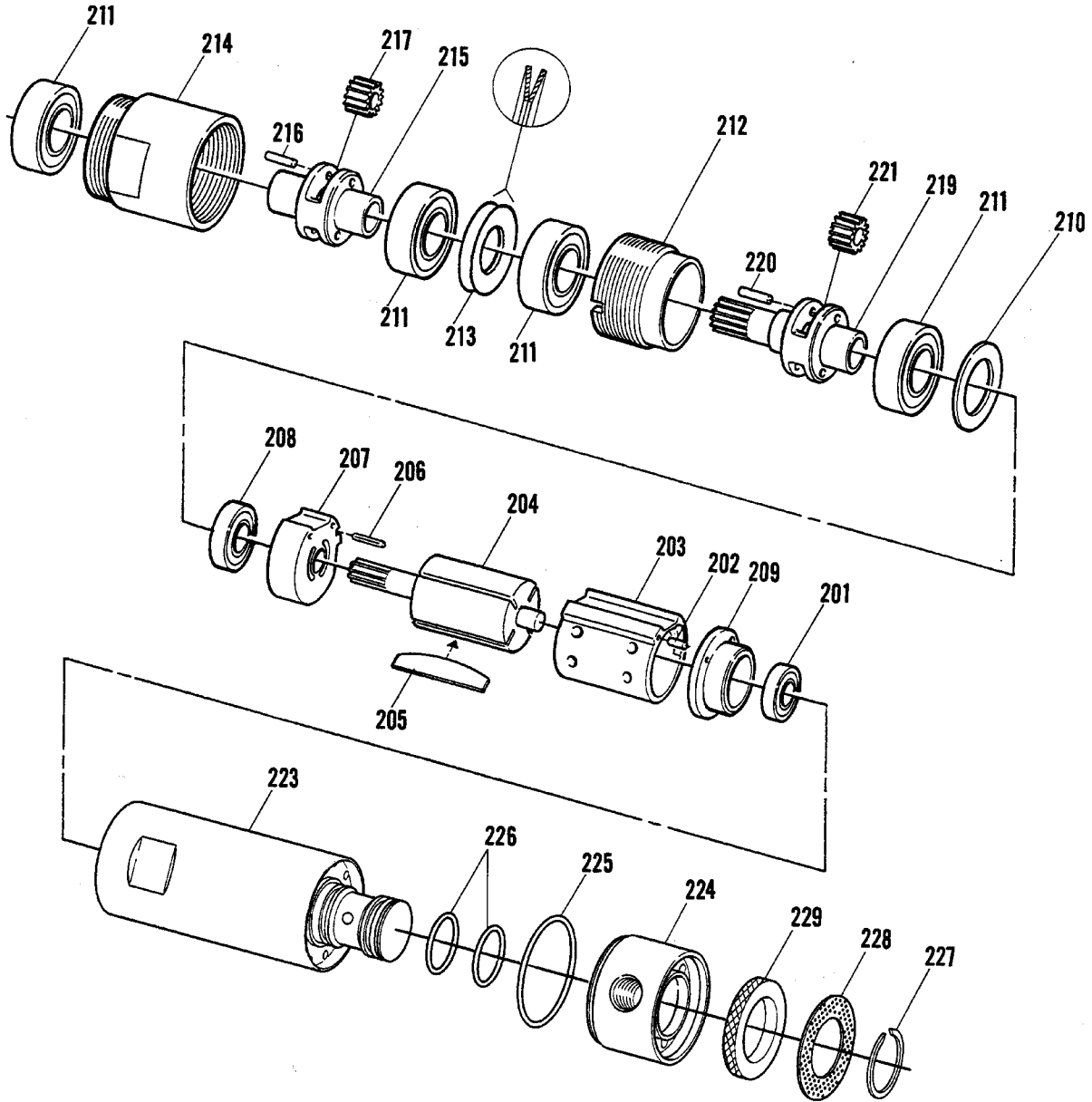

TROUBLESHOOTING

The following items are the most common tool symptoms if problems should occur. For symptoms or remedies not shown, contact your Signode service representative for additional information and details. The following tool symptoms are shown in this manual:

- #1 SYMPTOM: Inadequate strap tension.
- #2 SYMPTOM: Feedwheel milling or slipping.
- #3 SYMPTOM: Sealing & cut-off incomplete.
- #4 SYMPTOM: Strap slips through seal.
- #5 SYMPTOM: Low joint strength.
- #6 SYMPTOM: Seal buckles w/ strap slipping.
- #7 SYMPTOM: Seal slipping into nose of tool.

#1 SYMPTOM: INADEQUATE STRAP TENSION	
CAUSE	REMEDY
1. Improper strap being used.	1. Check that Signode lubricated strap is used.
2. Incorrect tool operating pressure.	2. Check that air pressure is set between 70-90 psig (4.8-6.2 bar).
3. Tension regulator set too low.	3. Adjust tension regulator of tool.
4. Clogged air supply components.	4. Check for particles restricting air flow in the regulator and filter (6).
5. Tool operating too dry.	5. Check lubricator operation and pour one tablespoon of lubricating oil into tool inlet.
6. Poor air delivery supply.	6. Check for restrictions or deterioration of supply hose.
7. Wear plug interfering with strap.	7. Check that wear plug (111) is not gouging strap.

#2 SYMPTOM: FEEDWHEEL MILLING OR SLIPPING	
CAUSE	REMEDY
1. Feedwheel teeth packed with dirt or grit.	1. Clean feedwheel teeth.
2. Feedwheel teeth worn or chipped.	2. Check feedwheel (88). Replace if teeth are broken or blunt.
3. Feedwheel clearance is excessive.	3. Check feedwheel clearance.
4. Inspect feedwheel shaft DU bearing (106) for extreme elongation.	4. Replace DU bearing if necessary.
5. Feedwheel mechanism does not pivot freely.	5. Check feedwheel pivoting for freedom of movement by squeezing the handle and air motor together.

#3 SYMPTOM: SEALING AND CUT-OFF IS INCOMPLETE	
CAUSE	REMEDY
1. Improper seals being used.	1. Check that the proper Signode seals are being used (See page 4 of this manual).
2. Incorrect tool operation pressure or tension regulator set too low.	2. A minimum of 70 psig (4.8 bar) is required to complete the sealing and cut off cycle. See the illustration on page 3 for the appearance of a properly notched seal.
3. Worn or broken sealer mechanism.	3. Check jaws (47), side plates (53, 56), notcher (48), cutter (57), or leading edge of tensioner foot (83). They should be reasonably sharp. Replace as required.
4. Worn or broken diaphragm (17).	4. Check diaphragm (17) for holes or tears. Replace if damaged.

#4 SYMPTOM: LOWER STRAP SLIPPING THROUGH SEAL	
CAUSE	REMEDY
1. Improper seals being used.	1. Check that the proper Signode seals are being used (See page 4 of this manual).
2. Incorrect tool operating pressure or tension regulator set too high.	2. Decrease tension by adjusting regulator of air motor.
3. Strap tail is too short.	3. Increase length of tail strap under seal.

#5 SYMPTOM: LOW JOINT STRENGTH	
CAUSE	REMEDY
1. Improper seals being used.	1. Check that the proper Signode seals are being used (See page 4 of this manual).
2. Worn or broken sealer mechanism.	2. Replace worn or broken jaws, notchers, side plates or pins.

TROUBLESHOOTING, Continued

#6 SYMPTOM: LOWER STRAP SLIPPING THROUGH SEAL AND SEAL BUCKLES	
CAUSE	REMEDY
1. Improper seals being used.	1. Check that the proper Signode seals are being used (See page 4 of this manual).
2. Incorrect tool operating pressure or tension regulator set too high.	2. Decrease tension by adjusting regulator on the air motor.

#7 SYMPTOM: SEAL SLIPPING INTO THE NOSE OF TOOL.	
CAUSE	REMEDY
1. Improper seals being used.	1. Check that the proper Signode seals are being used (See page 4 of this manual).
2. Worn tensioner foot.	2. Check slot in tensioner foot (83). Slot width should be .045" to .053" (1.15mm - 1.35mm). If opening exceeds this, check and replace if necessary.

TOOL OPTIONS

AIR MOTOR CONVERSION KIT, 424195

	KEY	QTY	PART #	DESCRIPTION
For use when replacing an older style PRHM motor (423700 or 306710) with the newer style motor (424160). This kit must be used to connect the motor to the cylinder.	125	1	250907	Reducing bushing, hex, 1/8 x 1/4
	41	1	016148	Pipe nipple
	73	1	422696	Fitting
	92	1	424271	Air line tubing
The following parts are included in this kit:	112	1	059918	Hex nut, 5/16-18
	113	1	171655	Nylon lockwasher
	114	1	171661	Steel collar
	115	1	024714	Screw

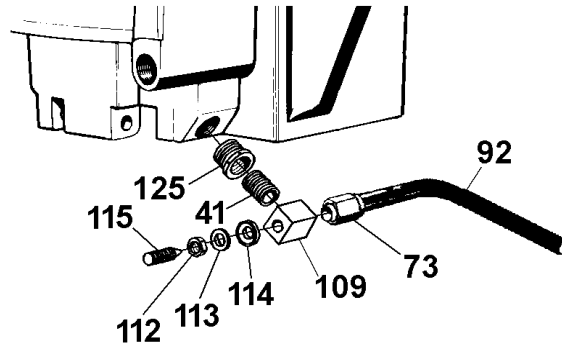



EU Declaration of Conformity
The Supply of Machinery (safety) Regulations
1992 (S.I. 1992/3073)

It is hereby declared that the undermentioned machinery has been designed and constructed to comply with the health and safety requirements defined in EC Directive 89/292/EEC

Machine Supplier: Signode, Division of ITW Ltd.
Queensway, Fforestfach
Swansea SA5 4ED

Machine Description: PRHM-34

Machine Type: Pneumatic Combination Hand Strapping tool.

Provisions with which machine complies:

89/392/EEC, 91/368/EEC

Harmonized EuroNorms with which machine complies:

EN 292:1, EN 292:2, EN 294, EN 349

Technical Standards with which machine complies:

NA

Signature: 

(Peter Oseland)

Date: 8 NOV 1994

SIGNODE NEW TOOL WARRANTY

Signode Engineered Products Warrants that a new Signode strapping tool will operate per functional specifications for a period of sixty (60) days after the date of shipment to the owner's place of business. Normal wearing parts, as outlined in the Operation, Parts & Safety manual, are covered by a thirty (30) day warranty unless, in Signode's judgement, these parts have been subjected to abnormal or extreme usage. Signode's sole liability hereunder will be to repair or replace, without charge, F.O.B. Signode's Glenview, Illinois plant, any tool which proves to not operate per functional specifications within the stated period. Signode reserves the right to replace any tool which proves not to operate per functional specifications with a new or like-new tool of the same model if in Signode's judgement such replacement is appropriate. Any new replacement tool provided to an owner will carry a full sixty (60) day warranty. Any warranty repaired tool or like-new replacement tool will carry a warranty for the balance of the time remaining on the initial sixty (60) day warranty. This warranty will be extended to compensate for the time the tool is in Signode's possession for warranty repairs.

This warranty is void as to any tool which has been: (I) subjected to mis-use, misapplication, accident, damage, or repaired with other than genuine Signode replacement parts, (II) improperly maintained, or adjusted, or damaged in transit or handling; (III) used with improperly filtered, unlubricated air or improper strapping material, (IV) in Signode's opinion, altered or repaired in a way that affects or detracts from the performance of the tool.

SIGNODE MAKES NO WARRANTY, EXPRESSED OR IMPLIED, RELATING TO MERCHANTABILITY, FITNESS OR OTHERWISE EXCEPT AS STATED ABOVE AND SIGNODE'S LIABILITY AS ASSUMED ABOVE IS IN LIEU OF ALL OTHERS ARISING OUT OF OR IN CONNECTION WITH THE USE AND PERFORMANCE OF THE TOOL. IT IS EXPRESSLY UNDERSTOOD THAT SIGNODE SHALL IN NO EVENT BE LIABLE FOR ANY INDIRECT OR CONSEQUENTIAL DAMAGES INCLUDING, BUT NOT LIMITED TO, DAMAGES WHICH MAY ARISE FROM LOSS OF ANTICIPATED PROFITS OR PRODUCTION, SPOILAGE OF MATERIALS, INCREASED COSTS OF OPERATION OR OTHERWISE.

Considerable effort has been made to ensure that this product conforms to our high quality standards. However, should you experience any difficulties, please contact your Sales Representative providing samples and the manufacturing code specified on the tool.

Thank you for your help.

SIGNODE ENGINEERED PRODUCTS
Hand Tool Division
3620 W. Lake Avenue, Glenview, Illinois 60025

PART #	DESCRIPTION	AREA OF USE
LUBRICANTS		
177029	BROWN K-55 GREASE	CLUTCH DRIVES, INTERNAL GEARS, GEAR SETS
422792	WHITE LUBRIPLATE GR-132 GREASE	PNEUMATIC PARTS, AIR CYLINDERS, AIR VALVES, O-RINGS
422793	BLACK LUBRIPLATE 3000W GREASE	MOVING INTERNAL PARTS, JAWS, LINKS
432322	EP ACCROLUBE GREASE	HIGH FRICTION CONTACT PARTS
008556	LS-1236 AIR LINE OIL	AIR MOTORS, AIR VALVES
ADHESIVES		
422794	LOCTITE #222, PURPLE	LOW STRENGTH, SCREWS 1/4" (6MM) OR SMALLER SIZES
422795	LOCTITE #242, BLUE	MEDIUM STRENGTH, SCREWS 5/16" (8MM) OR LARGER SIZES
422796	LOCTITE #271, RED	HIGH STRENGTH, SEMI-PERMANENT SCREW APPLICATION
422797	LOCTITE #609, GREEN	PERMANENT, CURVED SURFACE PART CONTACT
274111	LOCTITE #380, BLACK MAX	PERMANENT, FLAT SURFACE PART CONTACT
CLEANING BRUSHES		
023963	SMALL BRUSH	FEEDWHEEL & GRIPPER TEETH
269589	LARGE BRUSH	FEEDWHEEL & GRIPPER TEETH